

## SCHMIDT® ServoPress / TorquePress Manual Workstation with light curtain (LV)

SCHMIDT® ServoPress / TorquePress manual workstations are delivered ready for operation with press base, transparent protective guarding and light curtain. These systems are single workstations, which can be delivered with all SCHMIDT® ServoPress / TorquePress modules.

Included in the scope of delivery are:

- Module SCHMIDT® ServoPress / TorquePress mounted on a frame
- SCHMIDT® PressControl 5000 with pendant arm system
- Press base PU 10
- Transparent protective guarding with light curtain
- Distance light curtain adjustable in order to ensure a safe distance to the tool.
- Auxiliary control cabinet

All systems are EC type-approved.



# Workstations SCHMIDT® ServoPress

With Force outputs from 15 N to 150 kN



## Complete system with light curtain (LV)

Dimensions - single workstation		405	415 / 416	417	420	450 / 460
Width	<b>B</b> mm	~ 1120	~ 1120	~ 1120	~ 1120	~ 1120
Depth	<b>T</b> mm	~ 890	~ 890	~ 1140	~ 1140	~ 1100
Height	<b>H</b> min. mm	1880	min. 1880	min. 2570	min. 2630	min. 2810
Working area	mm	~ 850 x 700 x 650	~ 850 x 700 x 650	~ 850 x 700 x 650	~ 850 x 700 x 650	~ 875 x 980 x 650
Ram center - light curtain	mm	320	330	278,5 - 378,5	330 - 430	370 - 470
Weight	approx. kg	305	310	390	570	790

ServoPress typ		405	415/416	417	420	450/460
<b>Frame</b>						
Throat depth	<b>C</b> mm	130	130	150	160	160
Table bore	<b>D</b> Ø mm	20H7	20H7	40H7	40H7	40H7
Working height	<b>F</b> mm	246	300	387	515	512
Table height	<b>K</b> mm	93	113	128	155	190
Table size	<b>B x T</b> mm	160 x 140	220 x 175	250 x 200	300 x 220	370 x 230
Mounting surface	mm	160 x 345	220 x 405	250 x 460	300 x 563	370 x 635
	<b>O</b> Ø mm	9	11	11	13	13
	<b>SL 1</b> mm	50	80	80	85	95
	<b>SL 2</b> mm	220	250	250	300	350
	<b>SL 3</b> mm				50	50
	<b>SL 4</b> mm				350	400
	<b>SL 5</b> mm	325	390	430	528	600
	<b>SL 6</b> mm	345	405	460	563	635
	<b>SH 1</b> mm	510	630	780	1080	1050
	<b>SH 2</b> mm	1016	1100	1430	1835	2050
	<b>SB 1</b> mm	140	200	220	280	350
	<b>SB 2</b> mm	160	220	250	300	370

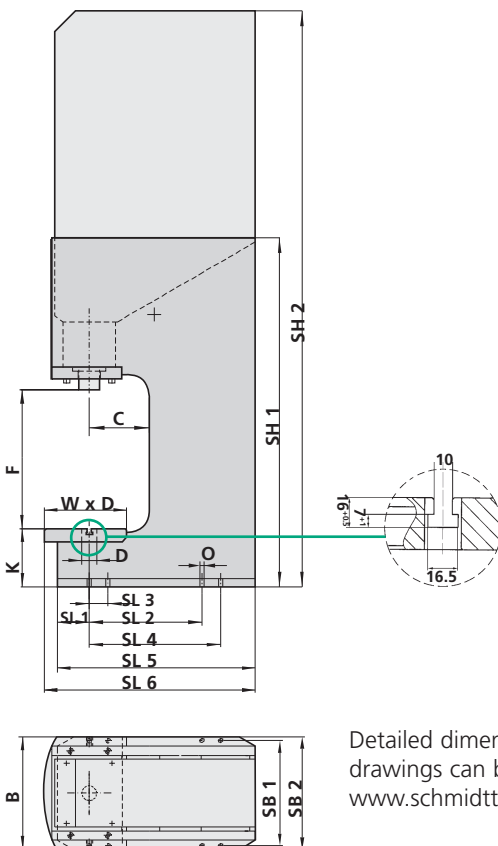

Detailed dimensional drawings can be downloaded:  
[www.schmidttechnology.de](http://www.schmidttechnology.de)

